

OT602

Addressable

Photo-electronic

Smoke Detector



Product Overview

OT602 Addressable Smoke Detector is designed in transnormal thin style. With a unique optical sensing chamber designed to sense smoke particles produced by a wide range of combustion sources. This chamber is protected by a fine mesh screen, which can be cleaned or replaced. It has automatic compensation for sensor contamination and complete self-diagnosis that can greatly reduce false alarm.

Characteristics

- Built-in microprocessor and intelligent software, ensuring the utmost accuracy with controller.
- 2 bus lines current PWM digital transmission technology with great reliability
- Special methods for damp-proof, antisepsis and mildew-proof.
- With inner mothproof net and shield cover
- SMT technology, firmly, high secure and anti-jamming.
- Easy plug-in of the head to base
- SEMS screws for easy wiring
- 2-wire without polarity
- Comply with Standard: GB4715-2005

Specifications

Operating Voltage: DC20V~DC30V

Standby current: ≤ 0.4 mA

Alarm current: ≤ 2 mA

Wiring: Non-polarized 2 bus lines

Address range: 1~192

Operating environment: Temperature: -10° C~ 50° C Related Humidity: $\leq 95\%$ ($40\pm 2^{\circ}$ C)

Dimensions: Diameter 100 mm Height 40 mm Weight: 82g

Configuration and Installation Guide

1. The Model of OT602 base is ODZ6004. Model 86H50 wall mounting enclosure or other enclosure with 40~85mm mounting hole space should be used.
2. The side of detector bottom and the side of base has one convex edge each. There is one slot on the base. When mounting, make the convex edge pointing to the slot in the base, and then place the detector into the slot. Finally turn clockwise until the convex edge of the unit is flush with the convex edge of base.

Wiring

1 and 2 terminals are connected to the corresponding terminals ZX+ and ZX- (without polarity) of fire alarm control panel.

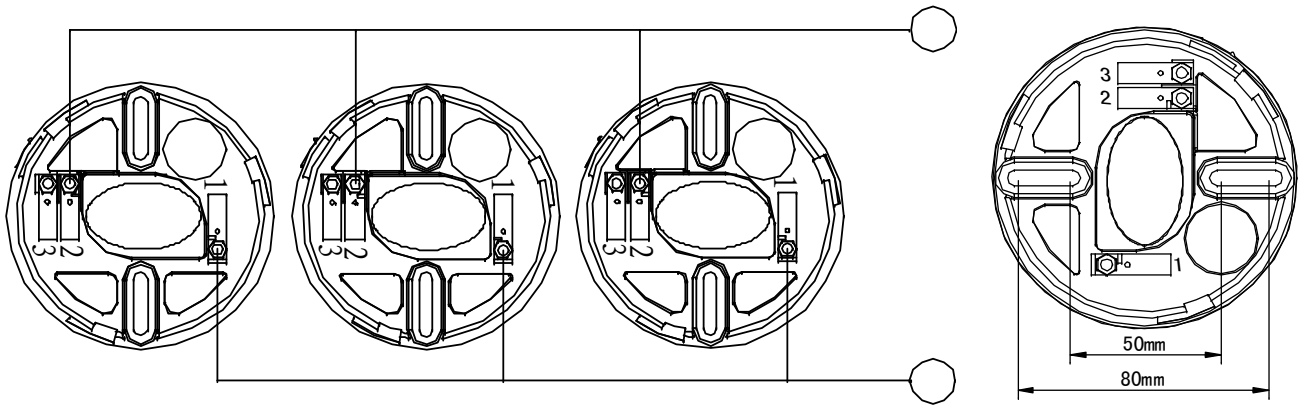

Notice

1. After installing, the detector has to be locked into the slots of base, and its convex edge should be flush with the convex edge of base. Otherwise, it will be reinstalled.
2. After installed onto the base, wire pipe on the ceiling should be sealed with sealing paste or sealing glue to prevent accumulated water going into the unit.
3. When connecting, the wire should be with cooled terminals or tinned, and can't be wound randomly.

Orena Sales and Service

Shenzhen Orena Photonic Technology Co. Ltd

Orena Bldg, No.691# Longjing Road, Nanshan District, Shenzhen, 518055, P.R.China

Ph: 86.755.2678.7499 86.755.8623.3886 Fx: 86.755.2678.7499

E-mail: oem@orena.com.cn sales@orena.com.cn www.orena.com.cn

Orena Group (Hong Kong) Limited

Rm 1105, Lippo Centre Tower 1, 89 Queensway, Admiralty, Hong Kong

Tel: 852.2537.7886 Fax: 852.2537.7780 www.orenahk.com